

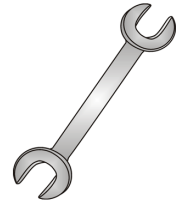

Tow-Trust Towbars

Important: Please read General Notes overleaf before fitting



Issue 1

TVW6SN VOLKSWAGEN PASSAT SAL & EST (B7) 2011>

Item	Qty	Description	Item	Qty	Description
A	1	Crossmember	E	2	M12 x 110 Grade 10.9 Bolts & Nyloc Nuts
B	2	Handed Side Arms	F	8	M12 x 40 Bolts, 2 Nuts & 8 S/P Washers
C	1	ACS9 / 9209 Swan Neck	G	2	15mm Spacer Plates
D	1	Flip Up Socket plate (TTFP/LH)	H	12	12 x 25 Flat Washers

1. Remove the rear light clusters.
2. Remove the rear bumper, two fixings around each wheel arch, one fixing behind wheel arch liner each side, two fixings below each light cluster and two fixings along the lower edge.
3. Pull bumper rearward.
4. Cut a section from the lower edge of the bumper (see sketch).
5. Remove the bumper beam. (This is not refitted with the Towbar).
6. Temporarily lower the heat shield.
7. Remove tape from the outer face of each chassis member covering the Towbar mounting holes.
8. Insert Items B into each correct chassis member and loosely bolt in place using Items F and Items H.
9. Using Items F and Items H bolt Item A between the handed side arms (Items B).
10. Using Items E and Items H and Item G bolt Item C and Item D to Item A.
11. Fully tighten all nuts and bolts ensuring the Towbar is rigid square and secure.
12. Refit the heat shield, rear bumper and light clusters.

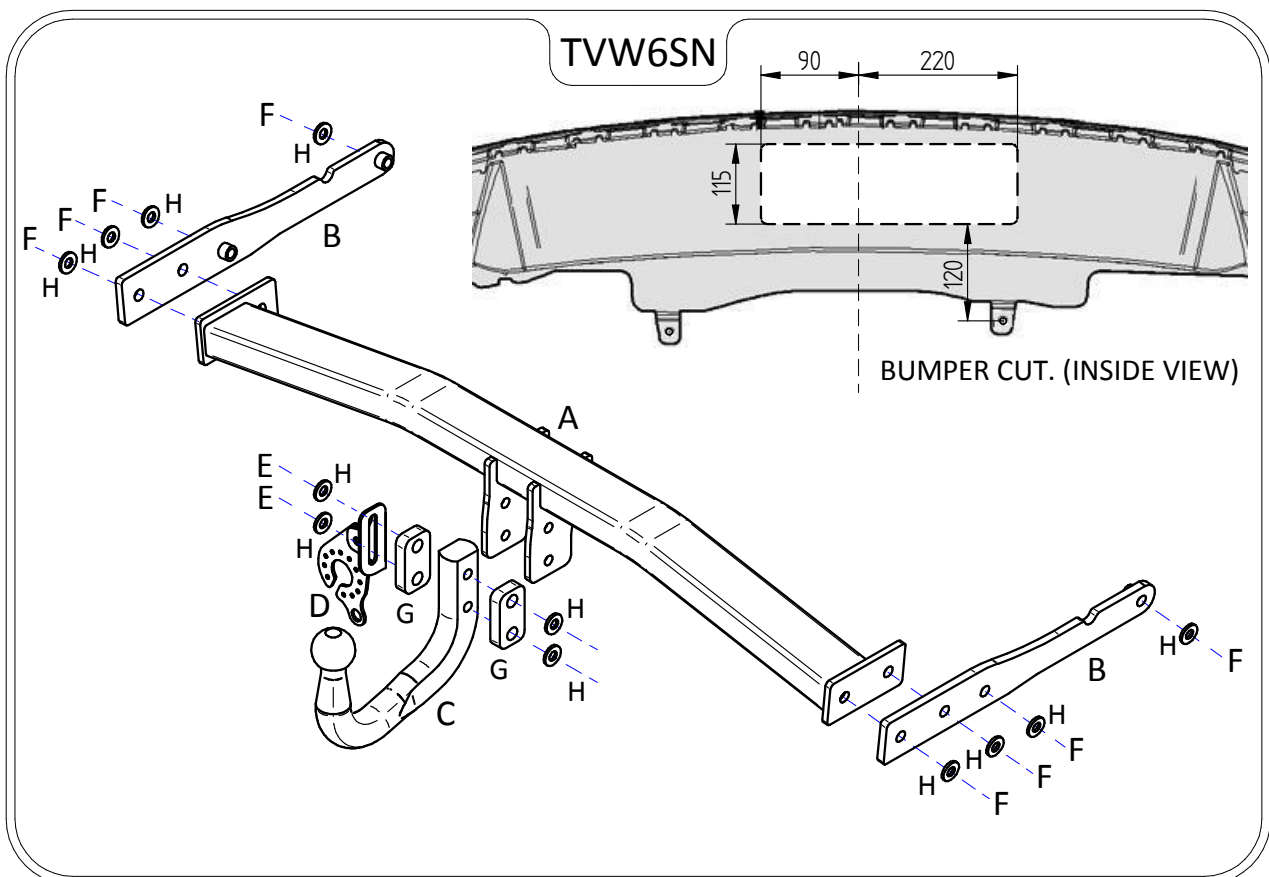

Note:

1. Recommended Torque Setting for M12 Grade 10.9 -139 Nm. (For other Torque Settings see notes overleaf.)
2. Nose load limits and vehicle manufacturers trailer / caravan weight limits must be observed.