

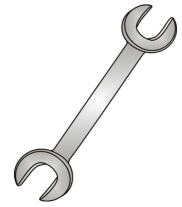

Tow-Trust Towbars

Important: Please read General Notes overleaf before fitting



Issue 3

TT7 TOYOTA AGENSIS SAL 2009>

Item	Qty	Description	Item	Qty	Description
A	1	Crossmember	D	2	M16 x 50 Bolts, Nuts & S/P Washers
B	2	Handed Side Arms	E	1	M12 x 100 Bolts & Nyloc Nut
C	1	Extension Bar	F	2	M12 x 40 Bolts & S/P Washers
			G	4	M12 x 35 Bolts, Nuts & S/P Washers
			H	1	6 x 30 Bolt and Flat Washers
			J	6	M12 x 50 x 1.25 Bolts & S/P Washers
			K	10	12 x 25 Flat Washers
			L	1	4.8mm x 16mm Rivet

1. Remove the lower rear under tray and Towing eye.
2. Remove heat shield. (**NOTE:** you may find it easier to access Towbar mounting points if you lower the rear silencer **PETROL MODELS ONLY**).
3. Locate Towbar mounting points on the lower face of each chassis member and clear off any mastic.
4. Using items J with item K loosely bolt items B to each correct chassis (**NOTE** on the nearside refit Towing eye onto side arm B to original mounting point)(**NOTE:YOU MAY FIND FITTING ITEM A EASIER IF YOU LEAVE R/H SIDE ARM OFF GET ITEM A INTO PLACE THEN FIT SIDE ARM (ITEM B)**).
5. Using items G bolt item A to side arms (item B).
6. Using item E with item K and item F with item K bolt item C to item A.
7. Bolt the ball bracket and wiring plate (not supplied in this kit) to item C using items D.
8. Fully tighten all nuts and bolts ensuring Towbar is rigid and secure.
9. Refit heat shield using longer bolt provided (item H) (if necessary rivet heat shield to the hole provided in item B).
10. Cut under tray as shown (SEE SKETCH) and refit.

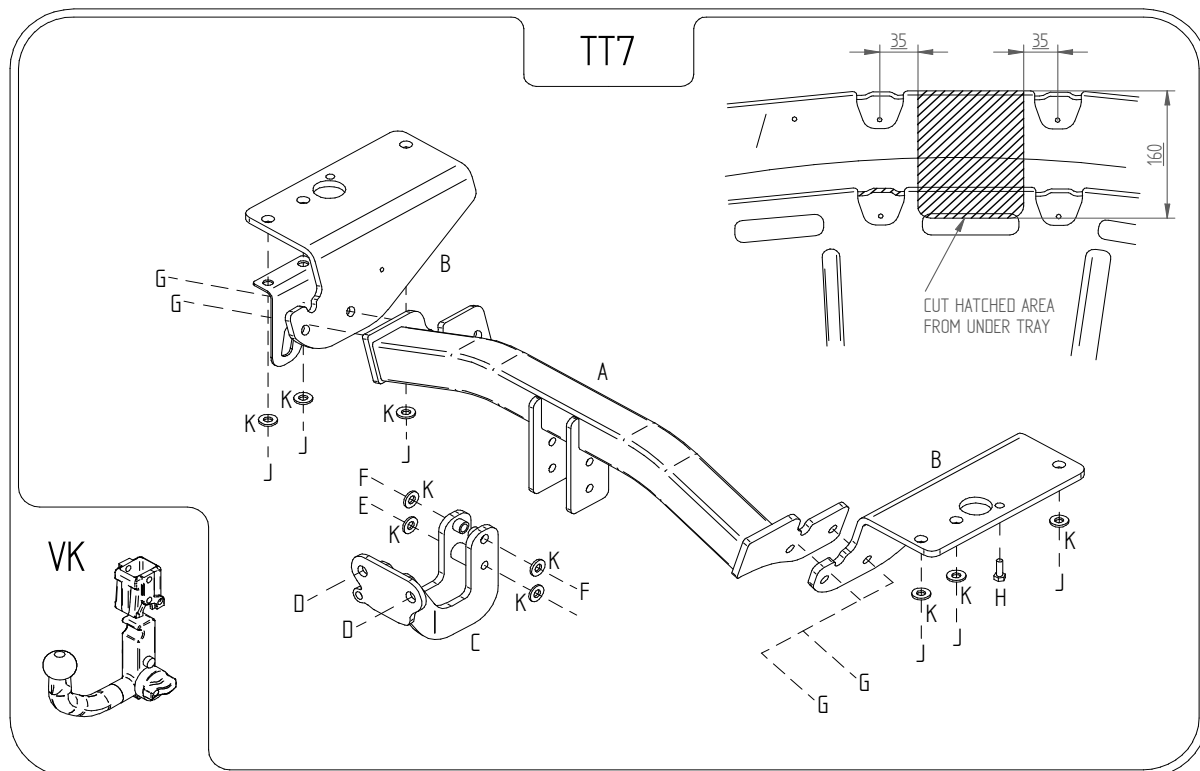

Note:

1. Recommended Torque Setting for M12 Grade 10.9 -139 Nm. (For other Torque Settings see notes overleaf.)
2. Nose load limits and vehicle manufacturer's trailer / caravan weight limits must be observed.