

TVOLV12SN VOLVO XC40 2018>

Item	Qty	Description	Item	Qty	Description
A	1	TVOLV12 Crossmember	D	1	VASP8 R/H Socket Plate
B	2	Handed Side Arms	E	6	M12 x 40 Bolts, 4 Nyloc Nuts & 2 S/P Washers
C	1	ACS9 / 9209 Swan Neck	F	2	M12 x 45 Bolts & S/P Washers
			G	2	M12 x 110 Grade 10.9 Bolts & Nyloc Nuts
			H	2	15mm Spacer Plates
			J	4	12 x 30 Flat Washers
			K	12	12 x 25 Flat Washers

BUMPER REMOVAL:

1. Open the rear tail gate and remove the bump stops found either side of the boot opening, remove by twisting 45 degrees and pull.
2. Remove four fixings from the bumper lower edge, five fixings from each wheel arch and release the bumper tips from the vehicle body then pull bumper rearward disconnecting any necessary wiring looms.
3. Remove rear impact beam (This is not refitted with the Towbar assembly).
4. Cut the rear bumper as per the sketch below.

TOWBAR INSTALLATION:

1. Insert Items **B** into each correct chassis member and fix in place at the forward most vehicle mounting point only using Item **E** and Item **J**.
2. Insert Item **A** into the open ends of each chassis and fix between each side arm using Items **E** with Item **K**.
3. Using Item **F** with Item **J** fix Item **A** and Items **B** through the rearmost vehicle mounting point.
4. Fully tighten all fixings ensuring the Towbar is rigid, square and secure.
5. Refit the rear bumper.
6. Fix Item **C** and Item **D** to Item **A** using Items **G** with Items **K** and Item **H**. (Note R-Design may require the socket plate to be fitted from the lower mounting point only)
7. Fully tighten all remaining fixings.

Bumper Cut Details Below

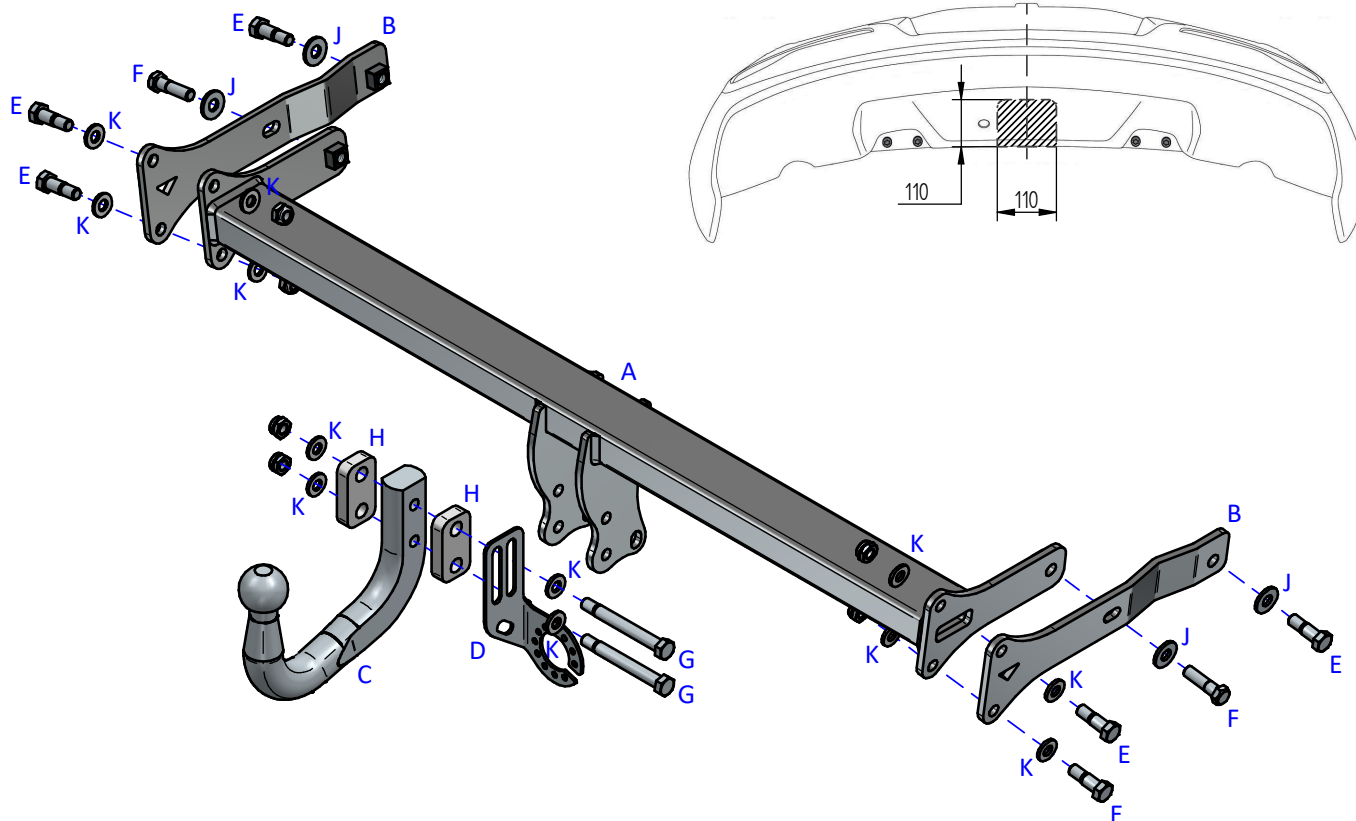

Notes:

1. For Torque settings see general notes overleaf.
2. Nose load limits and vehicle manufacturer's trailer / caravan weight limits must be observed.