

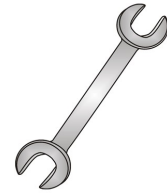

Tow-Trust Towbars

Important: Please read General Notes overleaf before fitting



Issue 7

TFD8 FORD TRANSIT 2014>

Item	Qty	Description	Item	Qty	Description
A	1	Crossmember	D	2	M16 x 60 Bolts & Nyloc Nuts
B	2	Handed Side Arms	E	4	M12 x 100 Grade 10.9 Bolts & Nyloc Nuts (110 Nm)
C	1	Coupling Spacer	F	4	M12 x 40 Grade 10.9 Bolts, 2 Nyloc Nuts & 2 S/P Washers
			G	4	M12 x 40 Thread Rolling Bolts & 12 x 40 Flat Washers (80 Nm)
			H	4	12 x 30 Flat Washers
			J	16	12 x 25 Flat Washers
			K	4	M12 Bolt Caps
			X	4	Ford Original Bolts (103 Nm)

1. Lower the spare wheel.
2. Remove the existing Ford bolts (Item X) from each chassis member and retain for fitting the Towbar assembly.
3. Using Item H as spacers loosely fix each side arm (Items B) to each chassis member using Items J and Item E (110Nm).
4. Using the original Ford bolts (Item X) fix the side arms (Items B) to the chassis members remaining fixing points. (103Nm).
5. Using Item G fix items B to the vertical points. **NOTE:** These are untapped holes and the bolts supplied are thread rolling bolts designed to cut their own thread. (80Nm).
6. Using Item F with Item J bolt Item A between Items B.
7. Using Item D and Item C bolt your desired ball bracket and wiring plate (not supplied in this kit) to Item A.
8. Fully tighten all nuts and bolts ensuring the Towbar is rigid, square and secure.

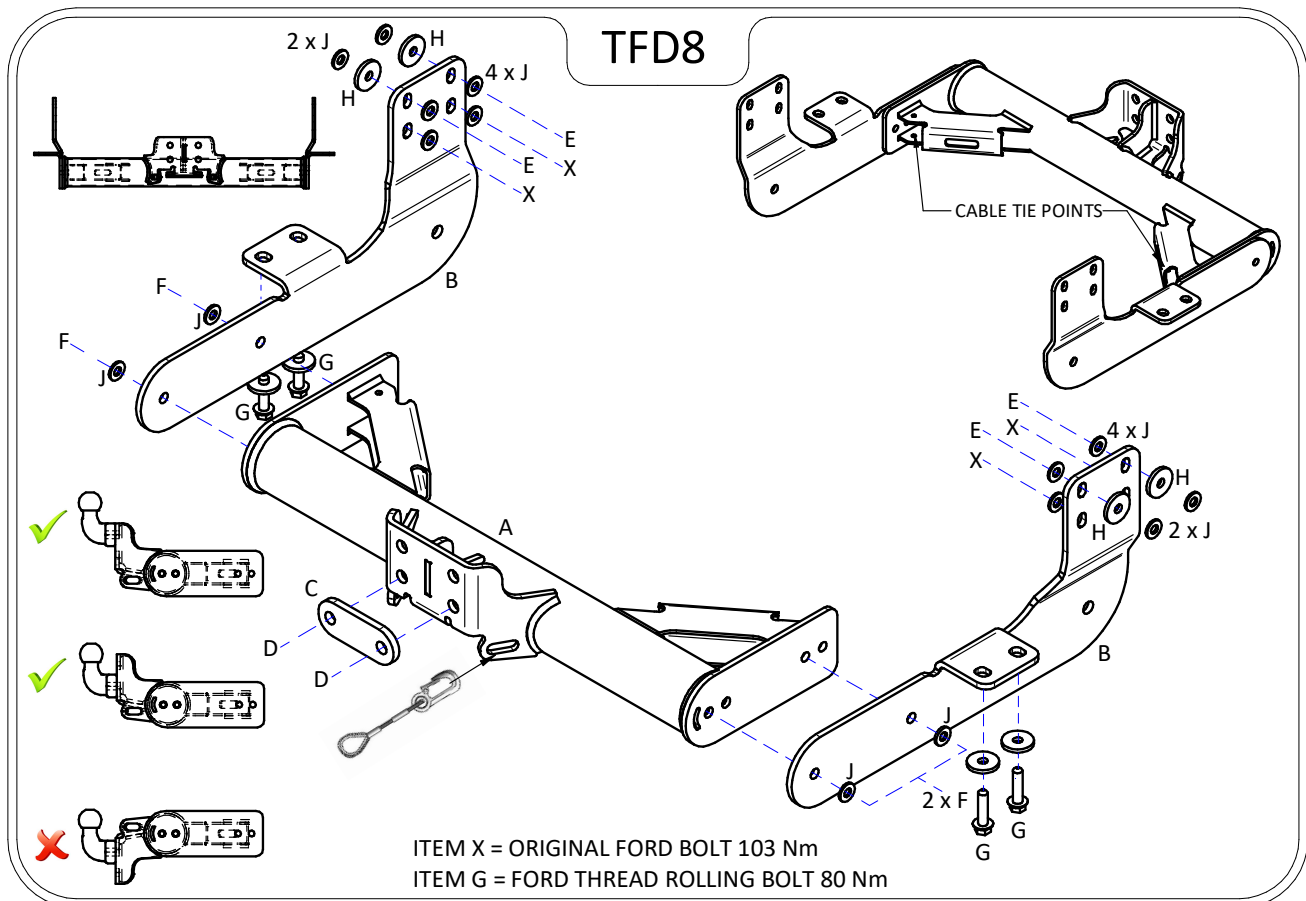

Note:

1. Recommended Torque Setting for M12 Grade 10.9 -130 Nm. (For other Torque Settings see notes overleaf.)
2. Nose load limits and vehicle manufacturers trailer / caravan weight limits must be observed.